

Campetto «M / L / XL» Underfloor distributor system

Manual

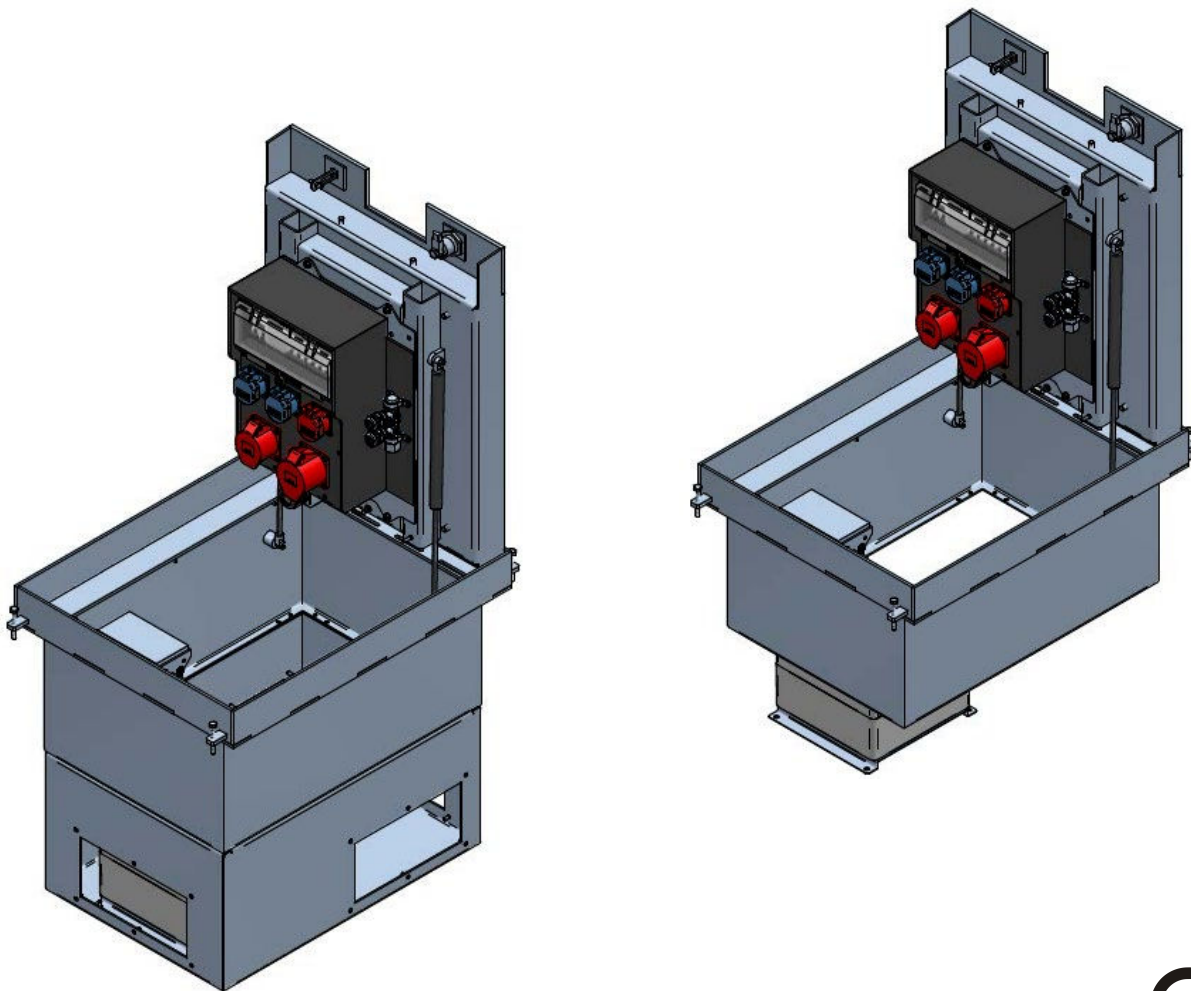

VERSION	MODIFICATIONS
1.0	First edition

Table of contents

1	General information.....	4
1.1	Marking concept for hazards and hints	4
1.2	Responsibilities of the operator.....	4
2	Applications.....	6
2.1	Product features and characteristics.....	6
2.1.1	The basic features and advantages of the Campetto M model are as follows:	6
2.2	Scope of delivery	6
2.3	Technical information	6
2.4	Set up.....	7
2.4.1	Article (Optional components).....	8
3	Introduction	9
3.1	Installation conditions Campetto 4 Underfloor distributor system.....	9
3.1.1	Work to be done on site by customer	9
3.2	Connecting underfloor distributor to power supply	11
3.2.1	Principle drawing.....	11
3.2.1	Observe during assembly.....	13
3.3	Electric power connection.....	14
3.4	General information on operation	14
4	Maintenance.....	15
4.1	Inspection and maintenance schedule.....	15
4.2	Description of maintenance and inspection works	15
5	Debugging.....	16
5.1	Measures for elimination of errors	16
5.2	Storage.....	16
5.3	Disposal of the device	16
6	Retrofitting instructions.....	17
6.1	Use of the chequered plate.....	17
6.1.1	Article.....	17
6.2	Step protection plate.....	18
6.2.1	Article.....	18

6.3	Support bracket for the slide / cable protection	18
6.3.1	Article	18
6.4	Coupling holder to CEE63/5 or CEE125/5	19
6.4.1	Article	19
6.5	Cable protection	19
6.5.1	Article	19
7	Service	20
7.1	Service addresses	20
7.2	Imprint	20

1 General information

1.1 Marking concept for hazards and hints

 **Hazard**

Hazardous situation which will cause serious injury or even death if it is not prevented.

 **Caution**

Hazardous situation which could cause slight to moderate injury if it is not prevented.

 **Hint**

Indicates information which does not concern personal injury, e.g. hints in respect of material damage.

 **Protective measures**

Increase safety by applying a protective measure.



The CE label confirms that your device satisfies the safety requirements set down in EU Directives 2006/95/EC and 2004/108/EC.

1.2 Responsibilities of the operator

- Make sure that this document is always kept in a safe place in a legible form together with the product.
- Read these instructions carefully before first start-up of the product.
- This product has been developed and produced exclusively for the use indicated in these documents. Every other use, which is not mentioned explicitly, could affect the intactness of the product and/or could constitute a source of danger.
- The manufacturer rejects any liability for damage which has been caused by incorrect or non-intended use of the product.
- In countries, which do not belong to the European Community, the national legal reference regulations as well as the standards and regulations applicable in these countries have to be observed for warranty of a corresponding safety level.
- The installation has to be carried out according to the applicable regulations.
- The manufacturer assumes no liability for inexpert execution of installation as well as deformations which may occur during operation.
- The electric power supply has to be switched off before executing any action on the installation.
- Exclusively original parts of the manufacturer shall be used for maintenance. Maintenance work may be carried out by qualified staff only.
- All procedures which are not explicitly mentioned by the manufacturer in the instructions are not permitted.
- The packing material must not be stored within the reach of children as it could be a potential source of danger.
- The product must not be installed in hazardous environments. Flammable gases or fumes represent a serious security risk
- Energy supply of the underfloor distributor has to be protected in accordance with applicable regulations and manufacturer's details.
- It must be checked whether the earthing system has been installed properly. The metal parts of the underfloor distributor must be connected to this system.

Created	Modified	Object-ID
01.04.2014 ROEN	09.01.2023 ROEN	2426109

- If a heating is installed by customer, it is important that the system will be protected by RCD 30mA.
- The manufacturer disclaims any liability with regards to safety and efficient operation of the underfloor distributor if components are used in the underfloor distribution system which were not approved by the manufacturer.
- On no part of the underfloor distributor changes should be made, under no circumstances.
- The installer has to provide the user with all information relating to the operation of the system.
- Make sure that underfloor distribution systems which can only be operated when they are in open mode, do not provoke any security risk during the operation (risk of unwanted closure of lid, manipulation, e.g.).
- Gas springs are wear parts and must be replaced immediately in case of pressure loss in order to ensure a safe and gradual closing of the cover (accident risk).

Any optional heating system (heating cover, etc.) may be installed only by authorized personnel.

Locking system, lid hinge bar and gas springs should be checked at appropriate intervals for cleaning and greasing.

The contact surface of the lid needs also to be cleaned from dirt in appropriate intervals to ensure a safe closing.

Bolts which are loose (by transport or installation e.g.) should be tightened.

The operator is responsible for draining any water arising inside the Campettos. (see also Chapter 3.1.1) The operator must guarantee and provide a proper drainage on-site.

2 Applications

GIFAS underfloor distributor systems are suitable for:

- Community and market places,
- warehouses, exhibition halls and trade fairs
- Hangars,
- Sport and leisure centres, parks,
- Pedestrian walkways and parking lots
- Shopping centres,
- Plants,
- etc.

... Electricity everywhere, where it is needed quickly, comfortably and regularly!

2.1 Product features and characteristics

2.1.1 The basic features and advantages of the Campetto M model are as follows:

- Open housing frame
- Pit cover for individual filling, with square lock
- Cover closed during operation
- Robust, easy to operate and reliable
- Vandal-proof solution
- Perfect visual integration in the overall appearance
- Different customised model sizes and distributor design options
- Low maintenance and servicing costs
- High-quality, sturdy and tested GIFAS hard rubber distributors
- Resistant to environmental conditions
- load capacity: 25t

Dimension, depth, lid strength and electrical installation equipment depend on customer's requests.

2.2 Scope of delivery

Campetto 4 including the electrical distribution and junction box are delivered ready-to-install. Cabling, filling with concrete, drainage e.g. has to be provided by customer.

For questions or queries, please contact our sales staff.

2.3 Technical information

- The Campetto 2022 model is available in 3 standard sizes [M / L / XL] (max. KSV 7900)
- Suitable for electric power, water and compressed air connections
- The GIFAS hard rubber distributor mounted on the cover can be individually configured
- The junction box is adapted to the connected loads and mounted in the housing
- The cover is available in a variety of load strengths (C250 is standard, with class B125 or A15 possible, depending on the special versions involved)
- Version in V2A stainless steel
- Rapid, easy opening and closing aided by gas springs, with the gas springs supporting the application of muscular force and ensuring controlled opening and closing of the GIFAS underfloor distributor systems
- The cover can be optionally fitted with a heating band

Created	Modified	Object-ID
01.04.2014	09.01.2023	2426109
ROEN	ROEN	

2.4 Set up

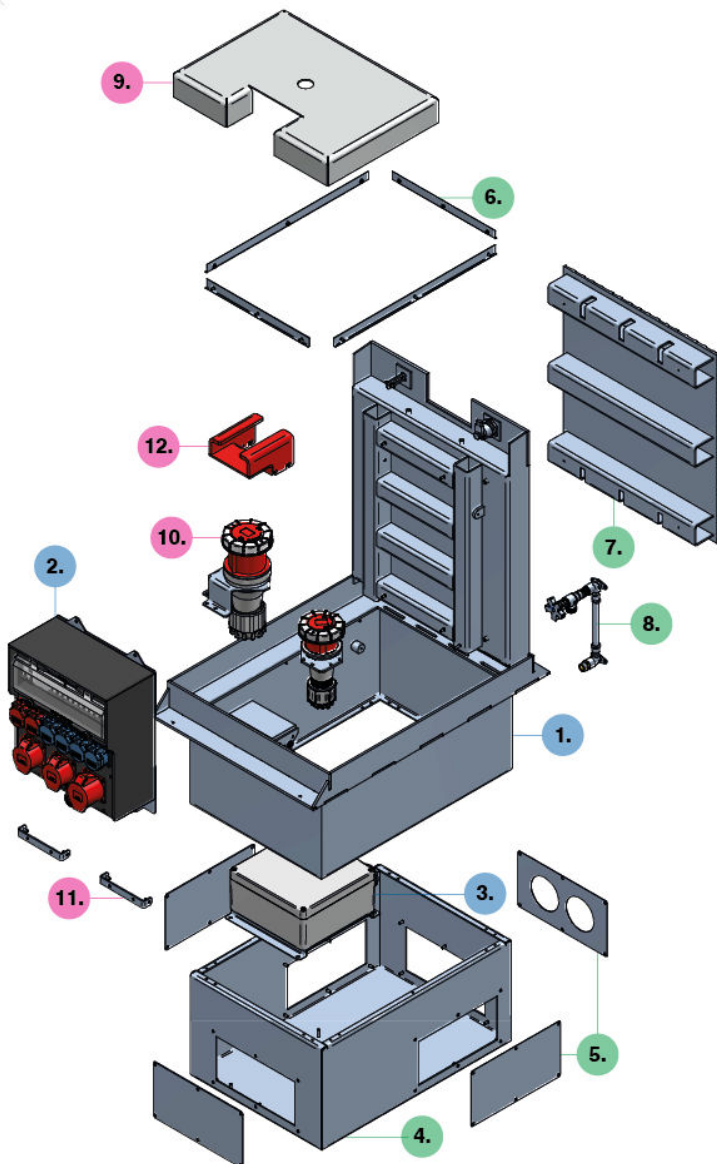

Base components

- 1) CAMPETTO with cover/frame
- 2) Power distribution box (on mounting plate)
- 3) Junction box (on mounting plate)

Optional components

- 4) Bottom part incl. drainage connection
- 5) Adapter plates for feeding lines
- 6) Heating cable/frame heating set
- 7) Chequered plate insert for cover
- 8) Water connection, 3/4", stainless steel

Accessories

- 9) Step protection plate
- 10) CEE63/5 or CEE125/5 coupling bracket
- 11) Mounting bracket for cable flap / cable protection
- 12) Cable protection

- The ordered product consists of items 1) to 8)
- The adapter plates 5) must be defined for the ordered product but are recorded separately and supplied as separate items.
- Accessories 9) to 12) can be retrofitted at a later stage

2.4.1 Article (Optional components)

- 209422 CAMPETTO M Lower section of fillable lid
- 209423 CAMPETTO L Lower section of fillable lid
- 209424 CAMPETTO XL Lower section of fillable lid

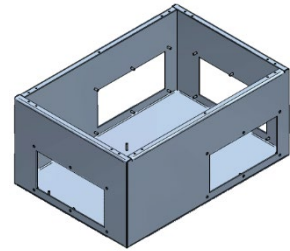

- 209399 CAMPETTO M/L/XL adapter plate 1x Ø115mm
- 209400 CAMPETTO M/L/XL adapter plate 1x Ø130mm
- 209401 CAMPETTO M/L/XL adapter plate 1x Ø55mm
- 209402 CAMPETTO M/L/XL adapter plate 1x Ø63mm
- 234860 CAMPETTO M/L/XL adapter plate 1x Ø63mm (not central)
- 209403 CAMPETTO M/L/XL adapter plate 1x Ø73mm
- 209404 CAMPETTO M/L/XL adapter plate 1x Ø95mm
- 209405 CAMPETTO M/L/XL adapter plate 2x Ø115mm
- 209406 CAMPETTO M/L/XL adapter plate 2x Ø130mm
- 209407 CAMPETTO M/L/XL adapter plate 2x Ø55mm
- 209408 CAMPETTO M/L/XL adapter plate 2x Ø63mm
- 209409 CAMPETTO M/L/XL adapter plate 2x Ø73mm
- 209410 CAMPETTO M/L/XL adapter plate 2x Ø95mm
- 209411 CAMPETTO M/L/XL adapter plate blind
- 230630 CAMPETTO Mounting set M6 for 4 adapter plates for lower section of fillable lid

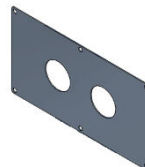
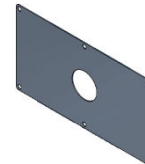

- 209413 CAMPETTO M Heating cover set
- 209414 CAMPETTO L Heating cover set
- 209415 CAMPETTO XL Heating cover set



- 224812 CAMPETTO M Chequered insert
- 224813 CAMPETTO L Chequered insert
- 224814 CAMPETTO XL Chequered insert

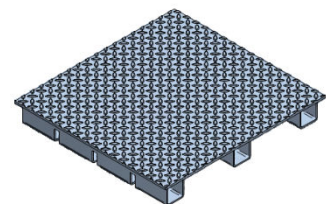

- 222512 Tap, stainless steel for Campetto



- 233393 Sash lock A2, square, 10mm. M36x1.5 (standard)
- 203501 Sash lock A2, semicircular
- 203503 Socket spanner, semicircular, V2A

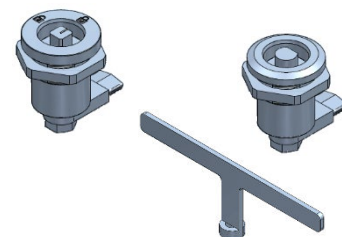

i Hint

The options for the basic selection should be defined in the quotation phase where possible

3 Introduction

To ensure proper installation, the following steps and notes must be complied with under all circumstances. Only this way can it be ensured that the product will work to complete satisfaction.

i Hint

Read all instructions before starting installation. Our sales department will be happy to answer any questions you may have.

3.1 Installation conditions Campetto 4 Underfloor distributor system

3.1.1 Work to be done on site by customer

The cover system is not sealed against surface water; this means that the customer must provide for the drainage of the underfloor distributor system. The customer must therefore ensure that an appropriate drainage line or drainage system is installed.

without drainage/Drain pipe



with drainage bed (e.g. loose subsurface)



With drain pipe (e.g. solid subsurface)



i Hint

Connecting a drain pipe is preferable to a natural drainage bed (soakaway). However, it must be ensured that the pipe is always open and drainage is guaranteed.

Check drainage capacity!

40L in 30 min.

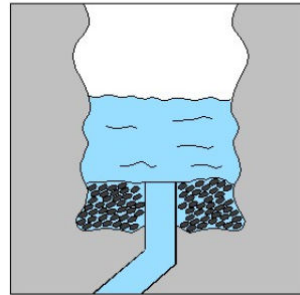

The excavation work as well as the professional and standards-compliant installation must be performed by the customer. It is important to ensure that the load capacity of the foundation and/or the cover layer corresponds to the load capacity of the underfloor distributor system in order to prevent subsidence. Delivery of concrete pipe has to be done on site by the customer.

⚠ Caution

If the Underfloor distributor system is to be used immediately after the excavation work, the installation pit must absolutely be secured or locked so that it does not pose a safety risk!

3.2 Connecting underfloor distributor to power supply

3.2.1 Principle drawing

The details necessary for proper installation can be found on the project-specific drawing from GIFAS. Custom models may vary from the following drawings.

The underfloor distributor system can be adjusted on the subfloor to the desired height (ultimate level of the finished floor) with the aid of levelling screws before applying the covering layer. Ensure that the underfloor distributor system is not in a depression to prevent the penetration of water.

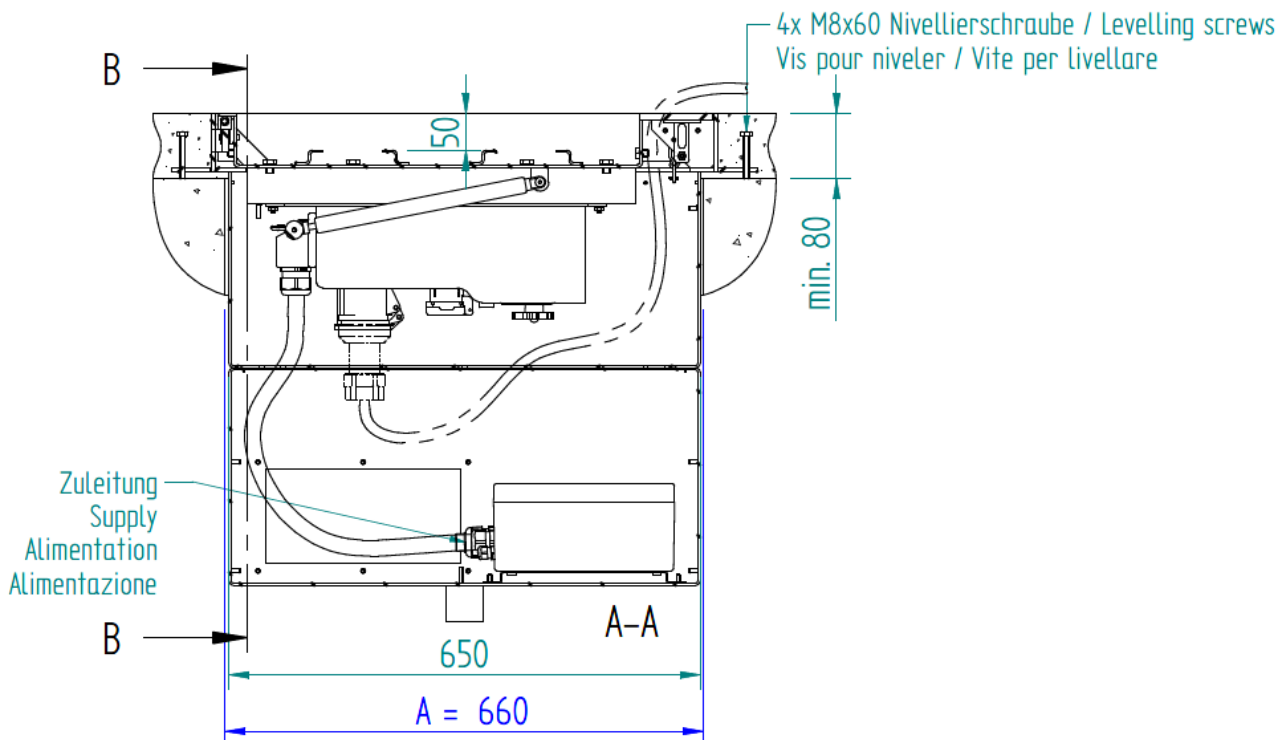

i Hint

The block-out dimensions “A x B x C” are also stated in the project-specific drawing provided by GIFAS.

Campetto M: 660 x 390 x 650

Campetto L: 660 x 460 x 650

Campetto XL: 860 x 510 x 750

i Hint

It is recommended that junction boxes at critical locations are filled with BLUE GEL.
 (Article 166534 [1]) / Article 174063 [2]) / Article 172210 [10])

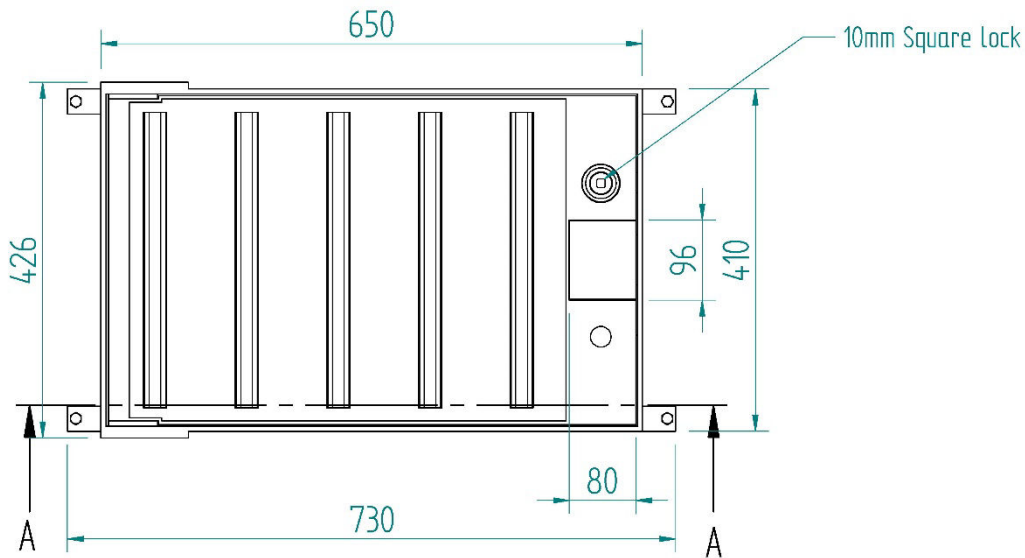

Hint

The built-in dimensions "A x B x C" can be found in the project-specific drawing provided by GIFAS

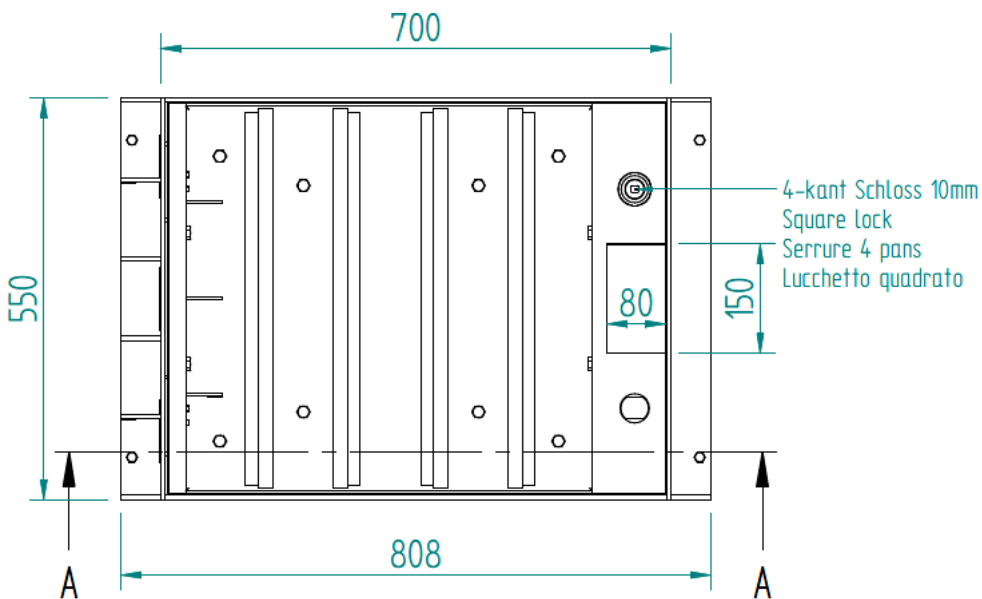

The cover opens automatically through the use of gas springs. They support muscular force and allow for the controlled opening and closing of the cover.

3.2.1 Observe during assembly

⚠ Hazard

Do not overfill the cover!

ℹ Hint

It is recommended that the metal of the fillable lid is pre-treated with primer (e.g. CTW) before filling. This improves the adhesion of the fill material to the metal.

Tolerance of top edge of filling or covering
+0/-1mm

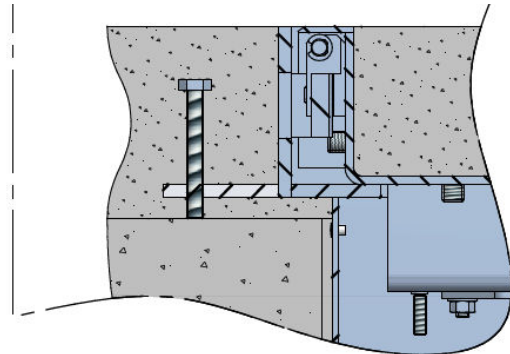

It is also recommended that all screws [M10] in the pit cover be retightened as these could loosen during transportation.

⚠ Hazard

Ensure that the frame is not warped.

No subsidence should occur in the surroundings!

ℹ Hint

The cover must be closed when filling around the Campetto. The Campetto should ideally be braced internally with wood and the gap wedged between the pit cover and frame.



⚠ Hazard

Ensure all-round clean flush contact of the frame.

ℹ Hint

If the cover layer (1) is not strong enough, and the Campetto was aligned with the levelling screws, the cavity between the concrete foundation (2) and the frame must be filled with concrete or an equivalent material. The frame must rest on a solid underground. The levelling screws and the bottom of the box have a no effect on the overall stability.

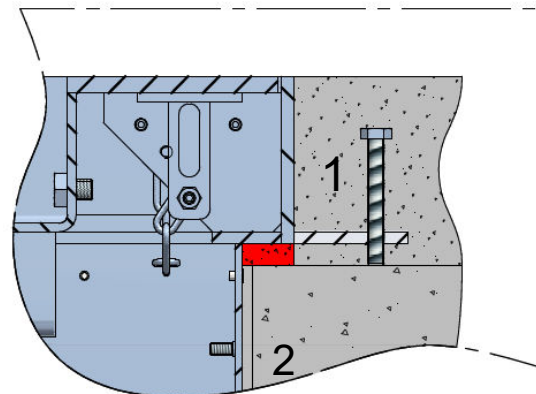

3.3 Electric power connection

⚠ Hazard

Connection to the grid should only be entrusted to trained and skilled personnel and is the responsibility of the operator.

The electric supply cable should be connected to the junction box by skilled personnel and an inspection of the Campetto conducted according to the following inspection plan.

3.4 General information on operation

The gas spring makes opening easier and the Campetto stays in the open position.

Check the floor pit after each use. Dirt and gauze must be removed accordingly.

If automatic protection flaps are installed in the distributor, tighten the knurled screws accordingly. This provides a higher IP protection (IP65).



The contact surfaces must be cleaned before closing. Dirt and stones must be removed.



If the Campetto is no longer required, the slider at the cable outlet opening must be set accordingly before closing.

Correct



Wrong



4 Maintenance

4.1 Inspection and maintenance schedule

Work to be done	Period
Test functioning of the gas spring(s)	1x year
Inspection of the lid hinge bar	1x year
Inspection of the lock system	1x year
Cleaning the lid cover surface	1x month
Clean the drainage	as needed / when dirty
Monitor the electrical distribution	according to country-specific regulations

Caution

Gas springs are wear parts and must be replaced immediately in case of pressure loss in order to ensure a safe and gradual closing of the cover.

4.2 Description of maintenance and inspection works

Lock system, lid hinge bar and gas springs need to be checked, cleaned and where necessary to be greased in appropriated intervals.

The lid surface needs to be cleaned from dirt in appropriate intervals, to ensure a safe and proper closing.

The underfloor distributor needs to be maintained and revised by professionally trained personnel, according to national regulations and standards.

5 Debugging

5.1 Measures for elimination of errors

Bug / error	Possible cause(s)	Solution
Cover can hardly be opened	Gas spring failure	Replace gas spring
Cover can hardly be opened	Dirty hinge or gas spring	Clean the hinge or gas spring
Cover closes too fast	Gas spring failure	Replace gas spring
Cover will not close	Cover surface dirty	Clean the cover surface
Cover will not close	Lock failure	Clean / change the lock
Cover jiggles	Hinge failure	Change the hinge
Earth leakage circuit breaker is triggering	Electrical fault	Repair by professionally-trained personnel

5.2 Storage

No additional measures are required for storage. With regard to packaging, pay attention to protection against damage.

5.3 Disposal of the device



This product must not be thrown in the garbage.

In accordance with official local and national regulations, this product is to be recycled appropriately.



European directive 2012/19/EU; waste electrical and electronic equipment (WEEE).

6 Retrofitting instructions

6.1 Use of the chequered plate

Please observe the following if use of the chequered plate is desired after delivery.

- Remove all screws [M10] in the pit cover

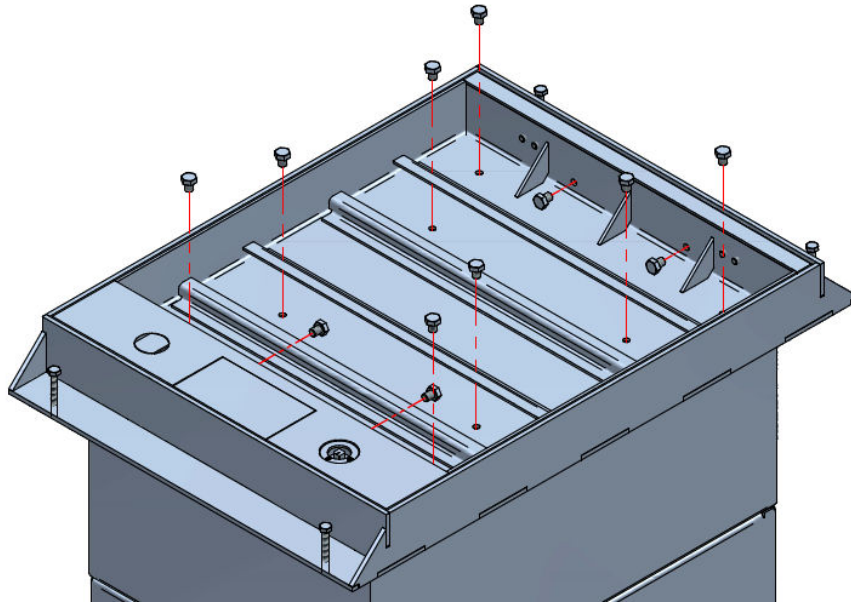

- Secure the chequered plate to the pit with four M6 screws

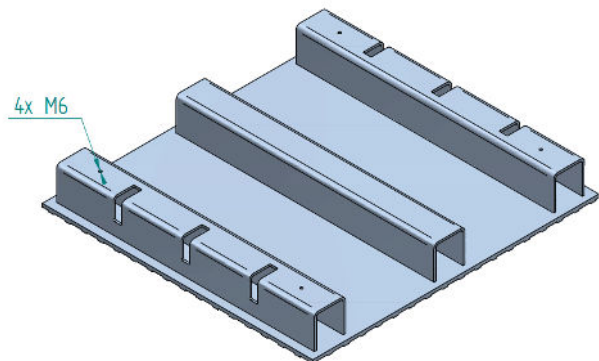
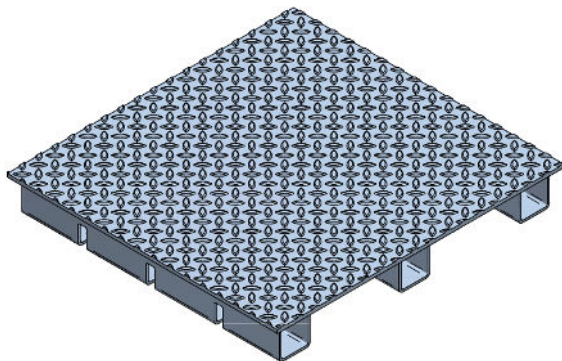

i Hint

The other M10 holes remain open as pit drainage openings.

If a chequered plate is retrofitted, the gas springs must be checked or redefined.

6.1.1 Article

224812	CAMPETTO M Chequered insert
224813	CAMPETTO L Chequered insert
224814	CAMPETTO XL Chequered insert

6.2 Step protection plate

The step protection plate can simply be laid on the frame. It can be deposited inside the Campetto if adequate space is available.

6.2.1 Article

224819	CAMPETTO M Step protection plate
224820	CAMPETTO L Step protection plate
224821	CAMPETTO XL Step protection plate

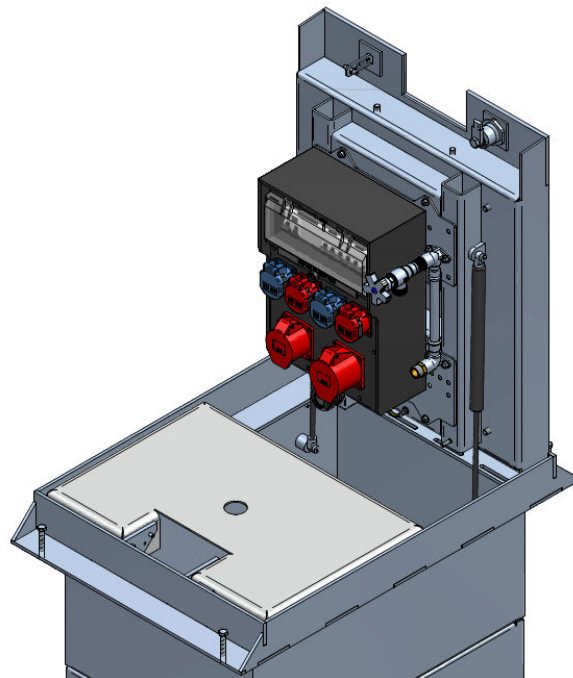

6.3 Support bracket for the slide / cable protection

The support bracket can be fitted in advance or retrospectively. Either the slide or cable protection can be deposited on the support bracket when not in use.

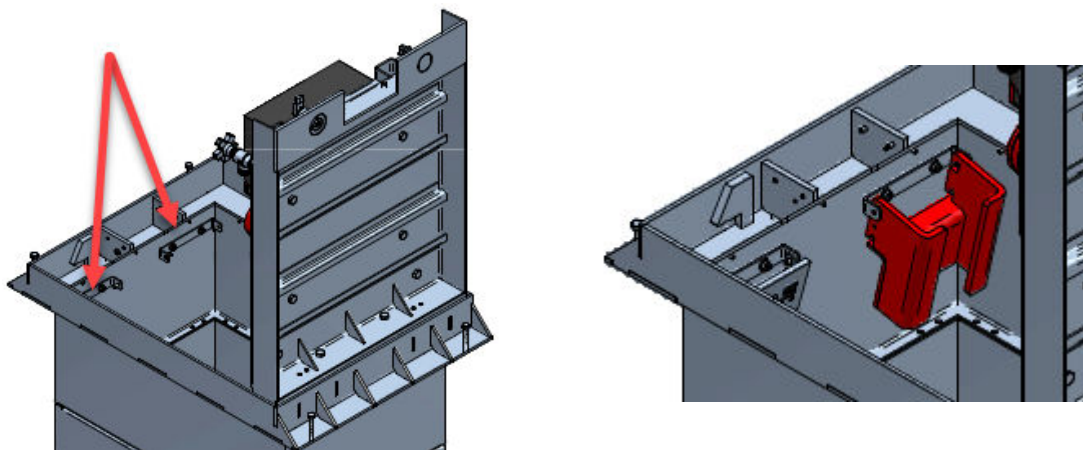

6.3.1 Article

209412	CAMPETTO M/L/XL Mounting bracket for slide / cable protection
--------	---

6.4 Coupling holder to CEE63/5 or CEE125/5

No support bracket can be provided for the slide or cable protection on the same side in the case of the CEE125 coupling holder.

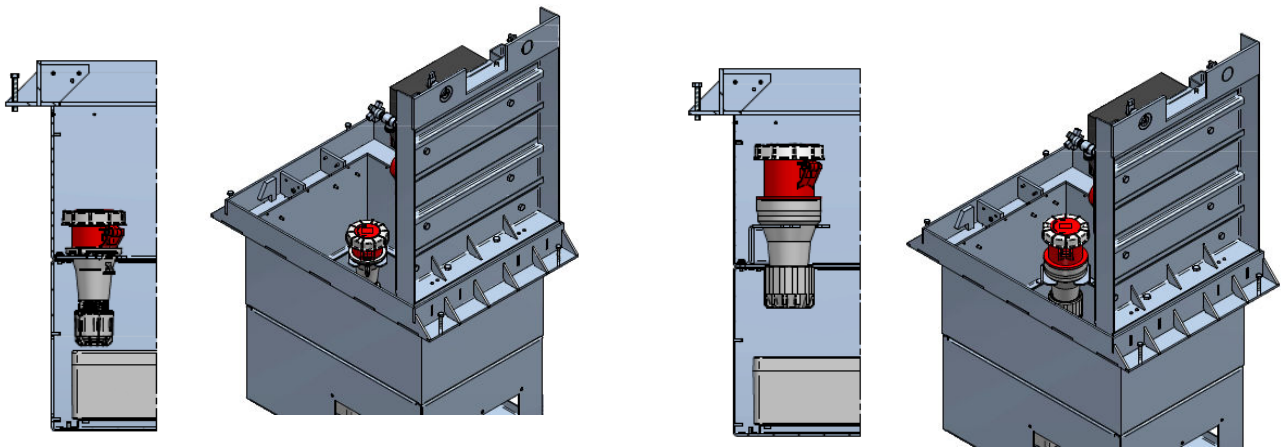

6.4.1 Article

- 224822 CAMPETTO M/L/XL coupling bracket CEE63
- 224823 CAMPETTO M/L/XL coupling bracket CEE125 (Observe installation situation)

6.5 Cable protection

Cable protection is provided to protect outgoing cables if the Campetto is closed or used with step protection. Practical depositing of the cable protection in the Campetto is achieved with a support bracket.

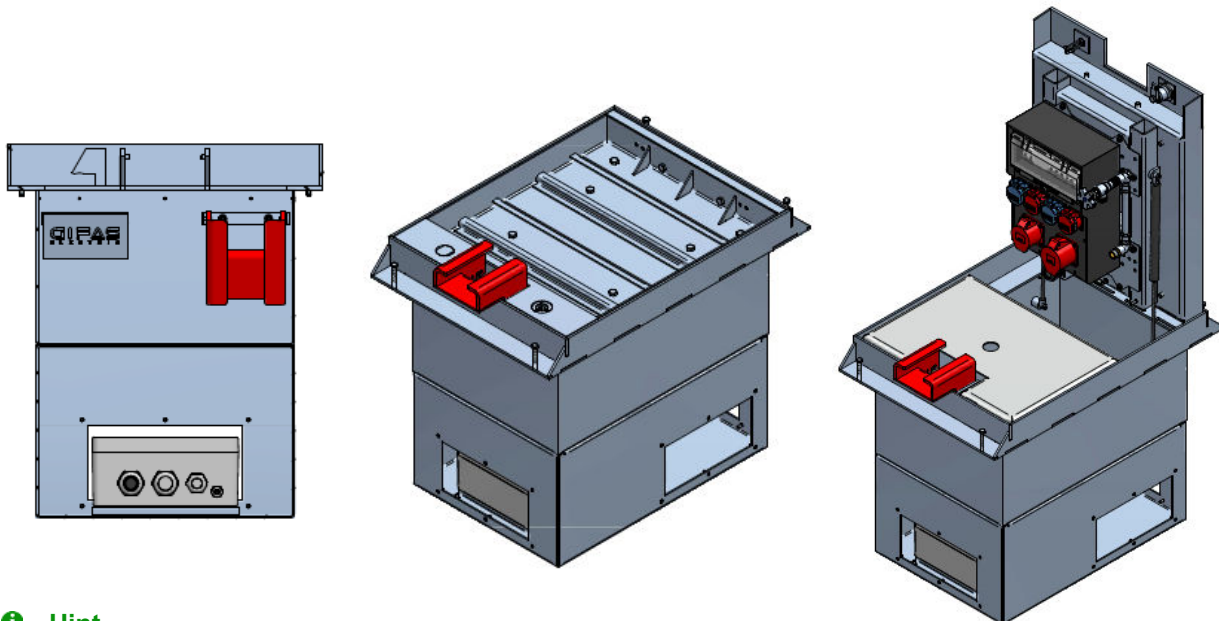

Hint

The decking must not protrude. This could lead to conflict with the setting of the cable protection.

6.5.1 Article

- 209416 CAMPETTO M/L/XL cable conduit

7 Service

7.1 Service addresses

GIFAS ELECTRIC GmbH Borsigstrasse 9 D-41469 Neuss	GIFAS-ELECTRIC S.r.l Via dei Filaracci 45 Piano del Quercione I-55054 Massarosa (LU)	GIFAS ELECTRIC GmbH Strass 2 A-5301 Eugendorf	GIFAS-ELECTRIC GmbH Dietrichstrasse 2 Postfach 275 CH-9424 Rheineck
☎ +49 2137 105-0 📠 +49 2137 105-230 🌐 www.gifas.de ✉ verkauf@gifas.de	☎ +39 58 497 82 11 📠 +39 58 493 99 24 🌐 www.gifas.it ✉ info@gifas.it	☎ +43 6225 7191-0 📠 +43 6225 7191-561 🌐 www.gifas.at ✉ verkauf@gifas.at	☎ +41 71 886 44 44 📠 +41 71 886 44 49 🌐 www.gifas.ch ✉ info@gifas.ch

7.2 Imprint

GIFAS-ELECTRIC GmbH
CH-9424 Rheineck
www.gifas.ch

Technical changes and errors reserved.

These installation instructions are the property of GIFAS-ELECTRIC GmbH and may not be copied, translated, transferred, duplicated or passed on to third parties without the previous written consent of GIFAS-ELECTRIC.

Created 01.04.2014 ROEN	Modified 09.01.2023 ROEN	Object-ID 2426109
--------------------------------------	---------------------------------------	-----------------------------