

TTV 1500 / TTV 3000

EN

OPERATING MANUAL
CONVEYING FAN



Table of contents

Notes regarding the operating manual..... 2

Safety 2

Information about the device..... 4

Transport and storage..... 5

Assembly and start-up..... 5

Operation 6

Available accessories..... 6

Errors and faults..... 7

Maintenance 7

Technical annex..... 7

Disposal 7

Notes regarding the operating manual

Symbols

 **Warning of electrical voltage**
This symbol indicates dangers to the life and health of persons due to electrical voltage.

 **Warning**
This signal word indicates a hazard with an average risk level which, if not avoided, can result in serious injury or death.

 **Caution**
This signal word indicates a hazard with a low risk level which, if not avoided, can result in minor or moderate injury.

Note
This signal word indicates important information (e.g. material damage), but does not indicate hazards.

 **Info**
Information marked with this symbol helps you to carry out your tasks quickly and safely.

 **Follow the manual**
Information marked with this symbol indicates that the operating manual must be observed.

 **Wear hearing protection**
Information marked with this symbol indicates that you should wear hearing protection.

You can download the current version of the operating manual and the EU declaration of conformity via the following link:

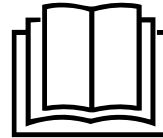

TTV 1500



<https://hub.trotec.com/?id=39417>

TTV 3000



<https://hub.trotec.com/?id=43011>

Safety

Read this manual carefully before starting or using the device. Always store the manual in the immediate vicinity of the device or its site of use!

 **Warning**
Read all safety warnings and all instructions. Failure to follow the warnings and instructions may result in electric shock, fire and / or serious injury. **Save all warnings and instructions for future reference.**
This appliance can be used by children aged from 8 years and above and persons with reduced physical, sensory or mental capabilities or lack of experience and knowledge if they have been given supervision or instruction concerning use of the appliance in a safe way and understand the hazards involved. Children shall not play with the appliance. Cleaning and user maintenance shall not be made by children without supervision.

- Do not use the device in potentially explosive rooms.
- Do not use the device in aggressive atmosphere.
- Set the device up in an upright and stable position.
- Observe a minimum distance of 3 m between walls, objects and the suction side.
- Let the device dry out after a wet clean. Do not operate it when wet.
- Do not use the device with wet or damp hands.
- Do not expose the device to directly squirting water.
- Never insert any objects or limbs into the device.
- Do not cover or transport the device during operation.
- Do not sit on the device.

- This appliance is not a toy! Keep away from children and animals. Do not leave the device unattended during operation.
- Check accessories and connection parts for possible damage prior to every use of the device. Do not use any defective devices or device parts.
- Ensure that all electric cables outside of the device are protected from damage (e.g. caused by animals). Never use the device if electric cables or the power connection are damaged!
- The electrical connection must correspond to the specifications in chapter Technical data.
- Insert the mains plug into a properly secured mains socket.
- Observe the technical data when selecting extensions to the power cable. Completely unroll the extension cable. Avoid electrical overload.
- Before carrying out maintenance, care or repair work on the device, remove the mains plug from the mains socket. Hold onto the mains plug while doing so.
- Switch the device off and disconnect the power cable from the mains socket when the device is not in use.
- Do not under any circumstances use the device if you detect damages on the mains plug or power cable. If the supply cord is damaged, it must be replaced by the manufacturer, its service agent or similarly qualified persons in order to avoid a hazard. Defective power cables pose a serious health risk!
- When positioning the device, observe the minimum distances from walls and other objects as well as the storage and operating conditions specified in the Technical data chapter.
- Make sure that the air inlet and outlet are not obstructed.
- Make sure that there are no loose items or dirt located in the immediate surroundings of air inlet and air outlet.
- Improper installation can lead to a fire, electric shock or severe personal injury.
- The device is provided with an overheating protection which is activated by overheating of the device (when exceeding the operating temperature). In such an event the device switches off automatically.

Intended use

The conveying fan TTV 1500 / TTV 3000 may be used for aeration, deaeration, air circulation, dust collection or air transport whilst adhering to the technical data and the safety instructions.

The device is designed for aeration and deaeration tasks, for the generation of a high air exchange rate even in shafts and ducts and over long distances.

Improper use

The conveying fan TTV 1500 / TTV 3000 is not suited for the installation in fluids or on flooded or boggy grounds.

Any unauthorised changes, modifications or alterations to the device are forbidden.

Personal protective equipment



Wear hearing protection

Wear appropriate hearing protection when working with the device.

Personnel qualifications

People who use this device must:

- be aware of the dangers that occur when using conveying fans.
- have read and understood the operating manual, especially the Safety chapter.

Residual risks



Warning of electrical voltage

Work on the electrical components must only be carried out by an authorised specialist company!



Warning of electrical voltage

Before any work on the device, remove the mains plug from the mains socket!
Hold onto the mains plug while pulling the power cable out of the mains socket.



Warning

Dangers can occur at the device when it is used by untrained people in an unprofessional or improper way! Observe the personnel qualifications!



Warning

The device is not a toy and does not belong in the hands of children.



Warning

Risk of suffocation!
Do not leave the packaging lying around. Children may use it as a dangerous toy.



Caution

Risk of injury due to parts being whirled up by the strong air current.
Before switching the device on, make sure that there are no loose parts (clothing, hair etc.) located near the air inlet or outlet!

Note

Do not use abrasive cleaners or solvents to clean the device.

Behaviour in the event of an emergency

1. In an emergency, disconnect the device from the mains feed-in: Switch the device off and disconnect it from the mains.
2. Remove persons from the danger area.
3. Do not reconnect a defective device to the mains.

Information about the device

Device description

The conveying fan TTV 1500 / TTV 3000 was designed for a high air volume flow.

The high air volume flow and a variety of configuration options enable its flexible application ranging from humidity regulation to the transport of fresh air or exhaust air over longer distances.

The device is equipped with bilateral hose connectors allowing to connect, for instance, an air transport hose to the air inlet and a dust bag to the air outlet. This makes the conveying fan an ideal transport fan for far-off connected air conditioning or heating applications. It thus allows to increase the conveying distance of warm or cold air.

When the device is not in use, the power cable can be wound around the air hose connection.

Device depiction

TTV 1500

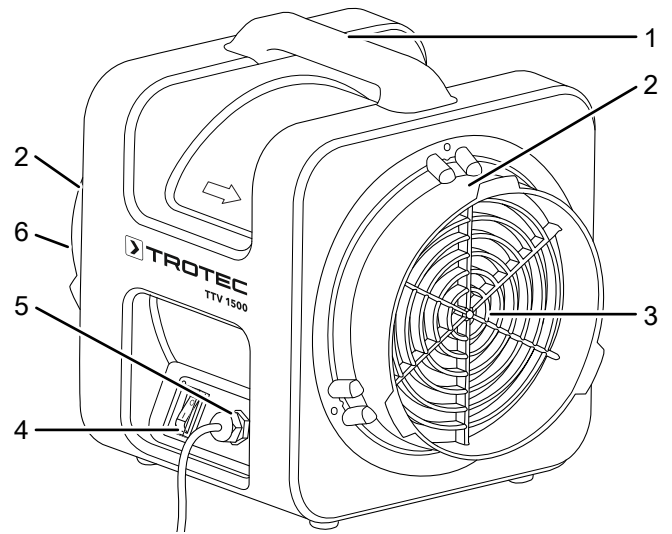

TTV 3000

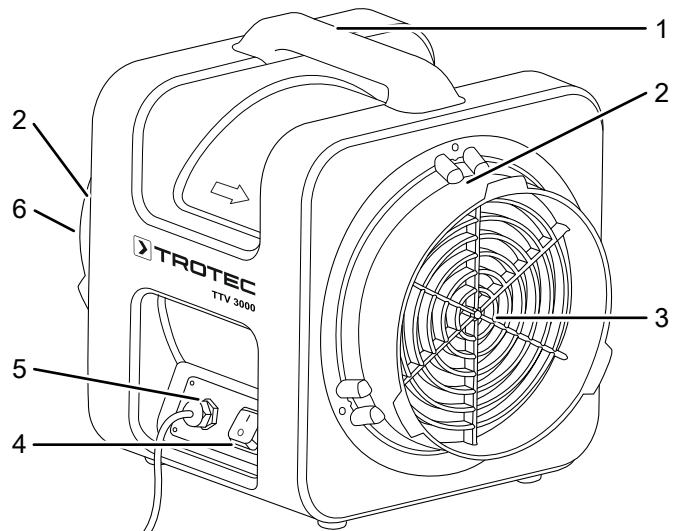

No.	Designation
1	Transport handle
2	Connector for air hose (optional)
3	Air outlet
4	On/off switch
5	Power cable
6	Air inlet

Transport and storage

Note

If you store or transport the device improperly, the device may be damaged.

Note the information regarding transport and storage of the device.

Transport

Before transporting the device, observe the following:

- Switch off the device.
- Hold onto the mains plug while pulling the power cable out of the mains socket.

After transporting the device, observe the following:

- Set up the device in an upright position after transport.

Storage

When the device is not being used, observe the following storage conditions:

- dry and protected from frost and heat
- in an upright position where it is protected from dust and direct sunlight
- with a cover to protect it from invasive dust, if necessary
- several devices may be stacked on top of one another



Info

Do not take the devices into operation when stacked. Stacking rules out an efficient usage of the devices.

Assembly and start-up

Scope of delivery

- 1 x Device
- 1 x Manual

Unpacking the device

1. Open the cardboard box and take the device out.
2. Completely remove the packaging.
3. Fully unwind the power cable. Make sure that the power cable is not damaged and that you do not damage it during unwinding.

Assembly

Connecting an air hose / a dust bag (optional)

1. Depending on the application, pull one or two air hoses (7) completely over the connectors.
2. When using a dust bag, pull it over the air outlet (3).
3. Fasten the air hoses or the dust bag by means of tension belts (8).

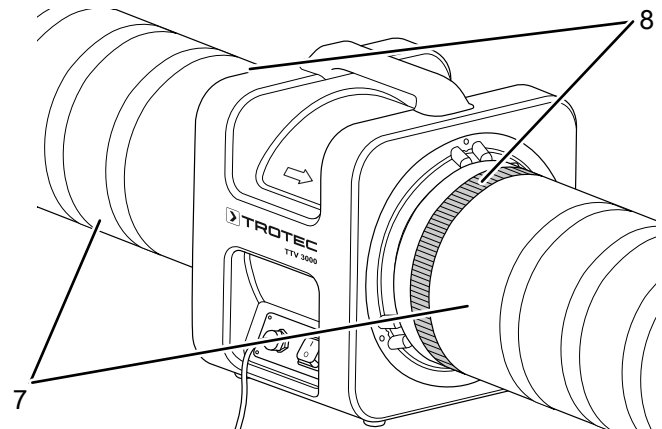

Start-up

When positioning the device, observe the minimum distance from walls or other objects as described in the Technical data chapter.

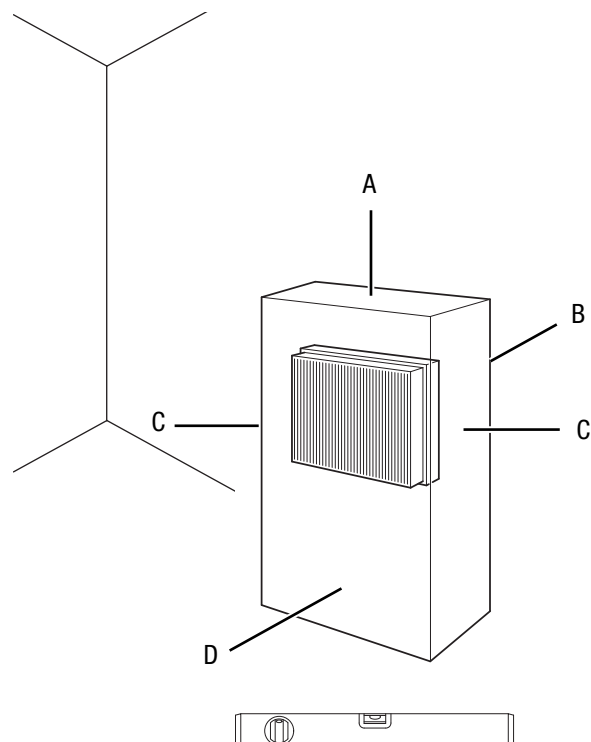

- Before restarting the device, check the condition of the power cable. If there are doubts as to the sound condition, contact the customer service.
- Set the device up in an upright and stable position.

- Make sure the device is only placed on firm, dry and vibration-free ground.
- When positioning the device, keep a sufficient distance to heat sources.
- Make sure that the air inlet and outlet are not obstructed.
- Make sure that extension cables are completely unrolled.

Connecting the power cable

- Insert the mains plug into a properly secured mains socket.

Operation

Operating elements

TTV 1500

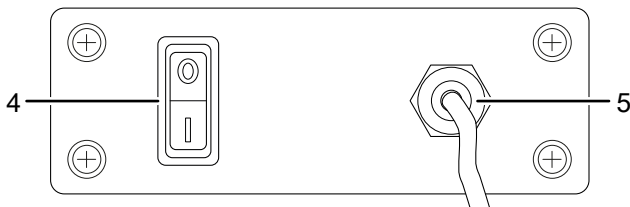

TTV 3000

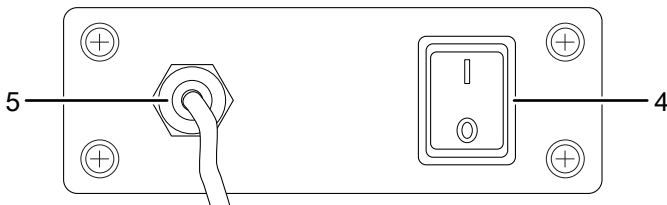

No.	Designation
4	On/off switch
5	Power cable

Switching the device on

1. Switch the device on by setting the on/off switch to position **I**.

Shutdown



Warning of electrical voltage

Do not touch the mains plug with wet or damp hands.

1. Switch the device off by setting the on/off switch to position **0**.
2. Hold onto the mains plug while pulling the power cable out of the socket.
3. Clean the device according to the Maintenance chapter.
4. Store the device according to the Storage chapter.

Available accessories



Warning

Only use accessories and additional equipment specified in the operating manual. Using insertion tools or accessories other than those specified in the operating manual may cause a risk of injury.

TTV 1500

Designation	Article number
Air transport hose Tronect SP-T, length 7.6 m	6.100.001.200
Dust bag, length 3 m	7.160.000.108
Universal tension belt	6.100.001.995
Replacement hose connectors	7.310.000.007

TTV 3000

Designation	Article number
Air transport hose Tronect SP-T, length 7.6 m	6.100.001.205
Dust bag, length 3 m	7.160.000.109
Universal tension belt	6.100.001.995
Replacement hose connectors	7.310.000.008

Errors and faults

The device has been checked for proper functioning several times during production. If malfunctions occur nonetheless, check the device according to the following list.

The fan is not running:

- Check whether the device is switched on.
- Check the power connection.
- Check the power cable and mains plug for damages.
- Check the on-site fusing.

The fan operates only for a brief period, then switches off:

- Check whether the protective grid at the air inlet is obstructed in some way. If applicable, remove foreign objects.
- The motor bearing might be damaged. Please contact the customer service.

Note

Wait for at least 3 minutes after maintenance and repair work. Only then switch the device back on.

Your device still does not operate correctly after these checks?

Please contact the customer service. If necessary, bring the device to an authorized specialist electrical company or to Trotec for repair.

Maintenance

Activities required before starting maintenance



Warning of electrical voltage

Do not touch the mains plug with wet or damp hands.

- Switch the device off.
- Hold onto the mains plug while pulling the power cable out of the mains socket.

Cleaning the housing

Clean the housing with a soft, damp and lint-free cloth. Make sure that no moisture enters the housing. Protect electrical components from moisture. Do not use any aggressive cleaning agents such as cleaning sprays, solvents, alcohol-based or abrasive cleaners to dampen the cloth.

Cleaning the fan and device interior

- Check fan and protective grid for perfect condition before and after each application.
- Clean the fan after each operation.
- Use compressed air to remove particles, lint, dust and dirt from motor, fan wheel and protective grid. Do not in any event use a high-pressure cleaner to clean the fan.
- Other than that, the device does not require maintenance.

Technical annex

Technical data

Parameter	Value	
Model	TTV 1500	TTV 3000
Article number	1.510.000.006	1.510.000.014
Amount of air	1050 m ³ /h	3000 m ³ /h
Air pressure	225 Pa	360 Pa
Voltage	230 V / 50 Hz	230 V / 50 Hz
Power input	0.17 kW	0.73 kW
Fusing	10 A	10 A
Transport medium temperature	max. 40 °C	max. 40 °C
Hose connector	Ø 200 mm	Ø 300 mm
Hose length	max. 15 m	max. 38 m
Sound pressure level (3 m distance)	71 dB(A)	77 dB(A)
Dimensions (L x W x H)	348 x 285 x 324 mm	470 x 390 x 460 mm
Minimum distance to walls and other objects		
	top (A): 0.5 m	0.5 m
	rear / suction side (B): 3.0 m	3.0 m
	sides (C): 0.5 m	0.5 m
	front (D): 0.5 m	0.5 m
Weight	8 kg	17 kg

Disposal



The icon with the crossed-out waste bin on waste electrical or electronic equipment stipulates that this equipment must not be disposed of with the household waste at the end of its life. You will find collection points for free return of waste electrical and electronic equipment in your vicinity. The addresses can be obtained from your municipality or local administration. For further return options provided by us please refer to our website www.trotec24.com.

The separate collection of waste electrical and electronic equipment aims to enable the re-use, recycling and other forms of recovery of waste equipment as well as to prevent negative effects for the environment and human health caused by the disposal of hazardous substances potentially contained in the equipment.

Trotec GmbH & Co. KG

Grebener Str. 7
D-52525 Heinsberg

☎ +49 2452 962-400

☎ +49 2452 962-200

✉ info@trotec.com

www.trotec.com